

XS-2B52



EXTREMA MACHINERY COMPANY, INC.

***PO BOX 1450, ALBANY, LOUISIANA 70711
(877) 398-7362 FAX (225) 567-2966***

TABLE OF CONTENTS

General Safety Rules	2
Shipping & Receiving Instructions	3
Unpacking & Checking Contents	4
Cleaning the Machine	4
Lifting the Machine	4
Installation Instructions	5
Connection to Air Supply Line	5
Electrical Safety Rules	6
Electrical Connection	7
Starting & Stopping the Machine	8
Abrasive Belt Oscillation & Tracking Safety	8
Tracking Adjustment	9
Abrasive Belt Tracking Device Illustration	9
Air Diagram	12
Adjustment of the Platen	13
Changing of an Abrasive Belt	14
General Maintenance of the Conveyor Belt	15
Maintenance of the Air Unit	16
Greasing & Lubrication	16
Disturbances	17
Deficiencies during the Sanding Operation	18
Deficiencies in the Sanding Pattern	19
Parts List	22

GENERAL SAFETY RULES

There is a certain amount of hazard involved with the use of woodworking machinery. Using the machine with the respect and caution demanded as far as safety precautions are concerned will considerably lessen the possibility of personal injury. However, if normal safety precautions are overlooked or ignored, severe personal injury to the operator can occur.

1. Read the operation manual before operating this machine.
2. If you are not thoroughly familiar with the machine operation, obtain advice from a supervisor or other qualified person.
3. The machine should be disconnected from the power source before performing maintenance or adjustments to the internal mechanisms, or when making repairs.
4. After maintenance job is finished, check to see if there are any tools or objects left on the machine. Close all safety guards.
5. Before leaving the machine, make sure the work area is clean.
6. Check timber for loose knots, nails, or other items, which may cause a hazard or affect the machine's performance.
7. Learn the machine's applications and limitations, as well as the specific potential hazards peculiar to it. Keep the machine in top condition for best and safest performance.
8. Keep all guards in place and in working order.
9. Do not force the machine. It will do the job better and be safer working at the rate for which it was designed.
10. All children and visitors should be kept a safe distance from the working area.
11. The operator should keep proper footing and balance at all times.
12. Do not operate the machine while under the influence of drugs, alcohol, or any other medication.
13. Avoid awkward operations and hand positions where a sudden slip could cause your hand to move into the machine.
14. Never leave the machine until it comes to a complete stop, and never leave the machine running unattended.
15. The employer is responsible for selecting competent and qualified employees.
16. The employer must make sure that employees study and utilize this safety information.
17. Supervisors must alert personnel of any unsafe practices they observe.
18. All employees should be aware of first aid facilities and be encouraged to use them, regardless of the severity of the injury.
19. Fire prevention must be practiced and must be available to prevent loss of life, personal injury, and property damage.
20. Safety shoes should be worn to provide protection against rolling objects, falling objects, and sharp edges in the workplace.
21. Eye protection should be worn and such devices should be carefully selected, fitted and used. Compulsory wearing of glasses with impact resistant lenses and side shields is a good safety policy. All eye protection should conform to ANSI 87 standards.
22. Wear hearing protection when operating the machine.
23. Do not wear rings, necklaces or jewelry around moving machinery.
24. Do not wear loose fitting clothes. Clothing should be comfortable, but long sleeves, neckties, etc. should not be worn.
25. Do not wear gloves or other hand covering articles around moving machinery.
26. Cover long hair with a hair net or cap.

27. Protective guards and shields must be in place at all items unless they must be removed for specific service or maintenance. They should be immediately replaced when service or maintenance is completed.
28. Make sure that operator clearly knows how to stop the machine before starting work.
29. Never clean or remove chips while the machine is running.
30. Maintain the machine in good operating condition. Report unusual conditions or machine malfunction immediately.
31. Do not alter or remove guards or warning labels.
32. Keep the immediate area clean. Do not allow the floor to become slippery, or covered with dust or obstacles. Dust that accumulates in the work area is a hazard that can cause you to fall or slip against the machine or its controls.
33. Employees should be required to report to their supervisors any hazardous condition of the machine or in the immediate area.
34. Be careful with your hands on the following spots when operating the sander.

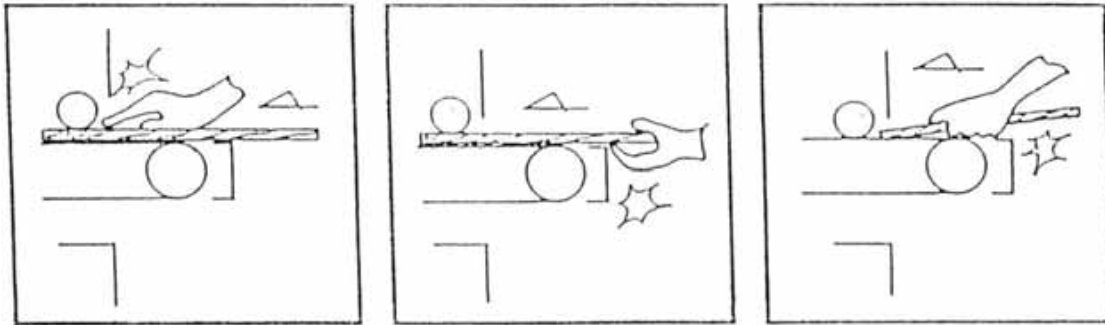

SHIPPING & RECEIVING INSTRUCTIONS

This machine has been carefully inspected and tested before packing. It was delivered in good condition and was shipped in one wooden pallet.

When receiving this machine, inspect the wooden pallet and check to see if there is any damage. Then check the machine model and all items as according to the packing list.

If there is any damage on the machine or any missing parts, report it to your local distributor or the machine manufacturer immediately.

UNPACING & CHECKING CONTENTS

The machine has been well packed at the manufacturer's factory and shipped in good condition. The machine is shipped in one wooden pallet.

Upon receiving the machine, carefully unpack it and check all items as according to the packing list.

If you find any part is missed or damaged, contact your local distributor or the manufacturer of the machine immediately. Do not attempt to operate the machine until the missing parts are obtained and are installed correctly.

CLEANING THE MACHINE

The machine is coated with rust preventative oil before shipment. When the machine has been moved to the proper work site, wipe the oil from the machine using a soft cloth soaked in kerosene. Do not use gasoline, lacquer thinner, or any other volatile solvent, as these may damage the paint surface of the machine.

LIFTING THE MACHINE

The machine should be lifted or moved by a forklift. Make sure the loading capacity of the forklift is sufficient to raise the machine. Pay special attention to the machine balance while lifting the machine to prevent the machine from falling. The forks of the forklift must protrude over the machine bottom for uniform distribution of the entire machine weight.

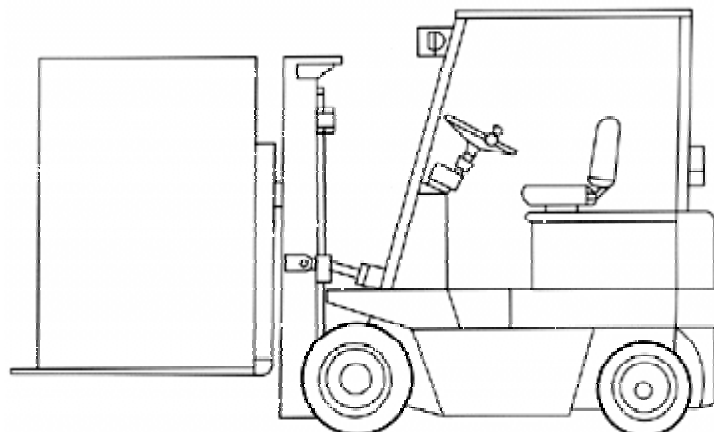

INSTALLATION INSTRUCTIONS

1. Upon arrival, the machine is to be checked as to damage that may have occurred during transport. In case of damage, the shipping company is to be informed as soon as possible and a corresponding complaint is to be made.
2. The machine is to be placed on a concrete foundation floor having a thickness of at least 9 inches and of such dimensions that the machine can be easily placed in position.
3. After removing the wooden case, move the machine to its foundation by means of lifting slings or a forklift truck.
4. The machine may be placed directly on the floor, and if preferred, may be bolted to the floor.
5. In order to avoid corrosion the blank parts of the machine have been treated with grease. This grease should be removed by using solvents.

CONNECTION TO AIR SUPPLY LINE

1. The machine is to be connected to an air supply unit that supplies a minimum pressure of 90PSI. We recommend the use of a refrigerated air dryer to remove all moisture from the airlines. Failure to use a refrigerated air dryer will void warranty on all pneumatic parts due to moisture related problems.
 - It should be checked whether this unit supplies dry and clean air. If this is not the case a special water separator and air filter must be installed in front of the machine, for even the slightest moist particle affects the interior of the machine and disturbs the optimal operation.
 - If the pressure is lower than 90PSI an extra buffer tank must be installed between the compressor and the machine.
 - Attention should be paid to the fact that the pressure may never drop below 70PSI, otherwise the belt control will be adversely affected.
2. The connection of the air supply hose into the machine must be done by means of a hose on the air filter situated at the right bottom side in front of the machine.
3. The reducing valve of the main connection has been adjusted by the manufacturer at 90PSI. Check this valve and readjust, if necessary, by turning the adjusting screw.
4. The machine should also be connected to an extraction unit of a satisfactory capacity.
 - The speed of the air in the suction pipe has to be minimum 90 ft./sec. The suggested suction pipe diameter is 6" for capacity 1300CFM.
5. Air-jet belt cleaner:
If the machine has been equipped with one or more air-jet belt cleaners, these must be connected separately to the air filter, which has been installed next to the air filter of the machine.

ELECTRICAL SAFETY RULES

1. Do not alter or bypass any protective interlock.
2. Before starting the machine, read and observe all warning labels and markings such as nameplates and identification plates.
3. Only personnel who are properly trained and have adequate knowledge and skill should undertake all electrical/electronic troubleshooting and repair.
4. Use extra precautions in damp areas to prevent yourself from accidental grounding.
5. Make sure your body and your tools are clear of electrical grounding.
6. The control panel doors should be opened only when it is necessary to check the electrical equipment or electrical wiring.
7. Before applying power to any equipment, establish without a doubt that all persons are clear.
8. Be alert and be sure you can work with no outside distractions.
9. Avoid wearing metal frame glasses or wearing a metallic necklace or chain, and never work on electrical equipment while wearing rings, watches, or bracelets.
10. When replacing conductors, make sure they conform to the manufacturer's specifications, including proper color-coding.
11. Do not alter the electrical circuits. If machine damage is caused by an unauthorized alteration, the user is responsible, not the manufacturer.
12. always assume the electrical power is ON and treat circuit as live. This caution develops a habit that may prevent an accident.
13. Give capacitors time to discharge. Otherwise, it should be done manually with care.
14. Use proper test equipment to make certain you have an open circuit. Test equipment must be checked and calibrated at regular intervals.
15. Open the control panel doors only when it is necessary to check the electrical equipment or disconnecting handle mechanism is its proper position.
16. All covers on junction boxes must be closed before leaving any job.

ELECTRICAL CONNECTION

An authorized electrician should do the electrical connection.

1. Check whether the main voltage is in accordance with the connecting voltage mentioned on the switch panel or wiring diagram.
 - The main cable should be screwed to the machine. The cable should be securely fastened to the wall and connected with a main switch.
2. Now the connections in the terminal box must be taken care of. Notice the correct connecting points (R-S-T- and Ground). The ground wire color should be green or yellow-green. To check proper rotation of the machine, press table up button. If the table goes down, switch the R and T wires.
3. Now the conveyor motor is to be started and check the right rotation of conveyor belt. Also, start the main motor and check the right rotation of the contact drum.
 - Tension should be placed on sanding belt before starting the main motor.
4. Close the cover of the terminal box carefully, so that no dust can accumulate in it.
 - Dust is the biggest enemy of electricity and could be the cause of many disturbances.
5. Also check the V-belt tension. The belt may be pushed together a maximum of $\frac{3}{4}$ " per belt. After two weeks of operations the V-belt tension must be checked again since these will be stretched initially.

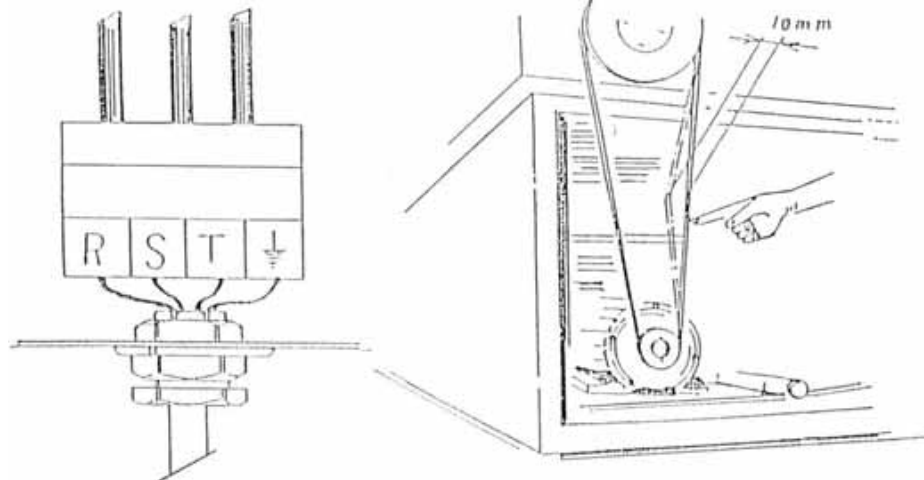

STARTING & STOPPING THE MACHINE

Before starting the machine all weekly or daily greasing points must be done.

A. Starting the Machine:

1. Open the aircock. Make sure the air pressure is at 90PSI.
NOTE: The machine cannot be started if the aircock is closed.
2. Start the dust extraction unit.
3. Apply tension to the abrasive belt by turning switch.
4. Now start the motor of contact roller by using the push button. Then start the motor of the sanding pad.
NOTE: If the tension roller has not set tension to the abrasive belt, the machine cannot be started.
5. Afterwards you can start the conveyor belt motor. It has a variable speed regulated by a hand wheel.
NOTE: Do not adjust the hand wheel when conveyor belt is stopped.

B. Stopping the Machine:

1. Switch the conveyor belt motor off.
2. Switch the contact roller and sanding pad motors off.
3. Wait until both aggregated have come to a complete stop.
4. If the machine has the air jet belt cleaner, switch it off now.
5. Shut off the aircock.

C. Emergency Stop:

Only use the emergency stop in the following situations:

1. The abrasive belt runs off or tears.
2. When something apparently goes wrong caused by an inexperienced maneuver.

For these purposes, press the big mushroom red button, which results in automatically braking of the aggregates and interrupting the current to the motors.

ABRASIVE BELT OSCILLATION & TRACKING SAFETY

1. Abrasive belt tracking is necessary to prevent the belt from running sideways.
2. Belt oscillation is through an electric eye system.
3. The abrasive belt tracking is achieved by changing the position of the tension (or idler) roller.
4. The tracking cylinder achieves movement of the tension roller.
5. In case of oscillation failure the abrasive belt will run sideways. An automatic brake system prevents the belt from being damaged.
6. Belt Oscillation Setting:
The stroke of the belt oscillation and the speed of oscillation can be set with speed controller. This speed controller regulates the pressure in the tracking cylinder.

TRACKING ADJUSTMENT

Check tracking by moving a piece of paper in and out of the electric eye. At this time, the tension roller should move from side to side. If the tension roller does not move, the electric eye and solenoid valve must be checked.

If belt runs to one side and the tracking cylinder is extended out full travel, loosen jam nut on cylinder and move the cylinder push cap out, or move the spring tension in.

If belt runs to one side and the tracking cylinder shaft is in, add spring tension by loosening jam nut, then turn the spring tension screw in.

ABRASIVE BELT TRACKING DEVICE ILLUSTRATION

1. Abrasive Belt Tracking Cylinder
2. Locking Nut
3. Tracking Angle Adjusting Nut
4. Rod End Bearing
5. Air Speed Control Valve (Backward)
6. Air Speed Control Valve (Forward)

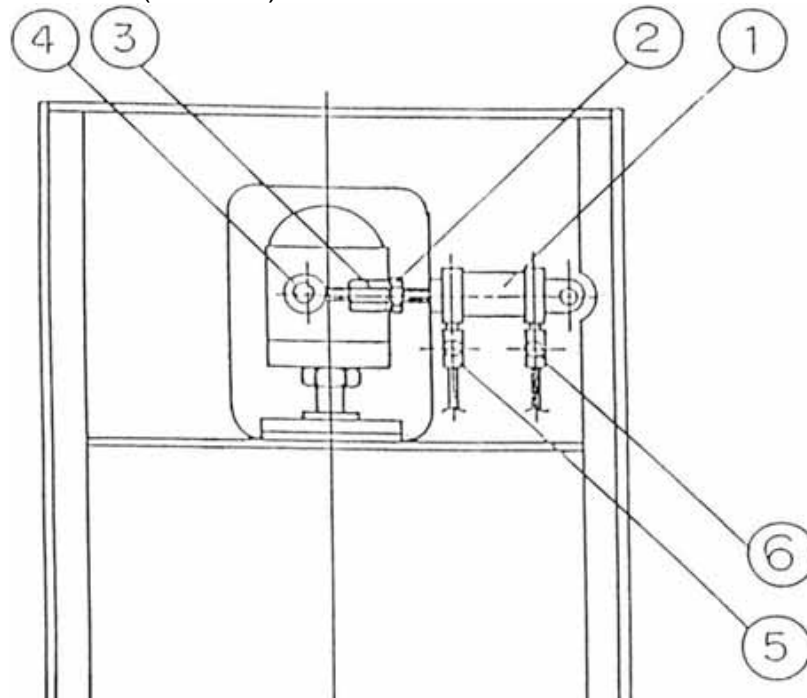

Tracking Instructions:

1. Start on the main motor after the abrasive belt and the tension cylinders were checked correctly.
2. If the abrasive belt goes to outside direction, then loosen the locking nut and turn the adjusting nut clockwise.
3. If the abrasive belt goes in the inside direction, then turn the adjusting nut counter-clockwise.

AIR DIAGRAM

1. Air Supply Valve
2. Turning Switch (for abrasive belt tensioning)
3. Tension Cylinder
4. T-Way
5. Solenoid Valve (for brake oscillation)
6. Brake Cylinder
7. Solenoid Valve (for abrasive belt oscillation)
8. Speed Control Valve
9. Tracking Cylinder
10. Electric Eye

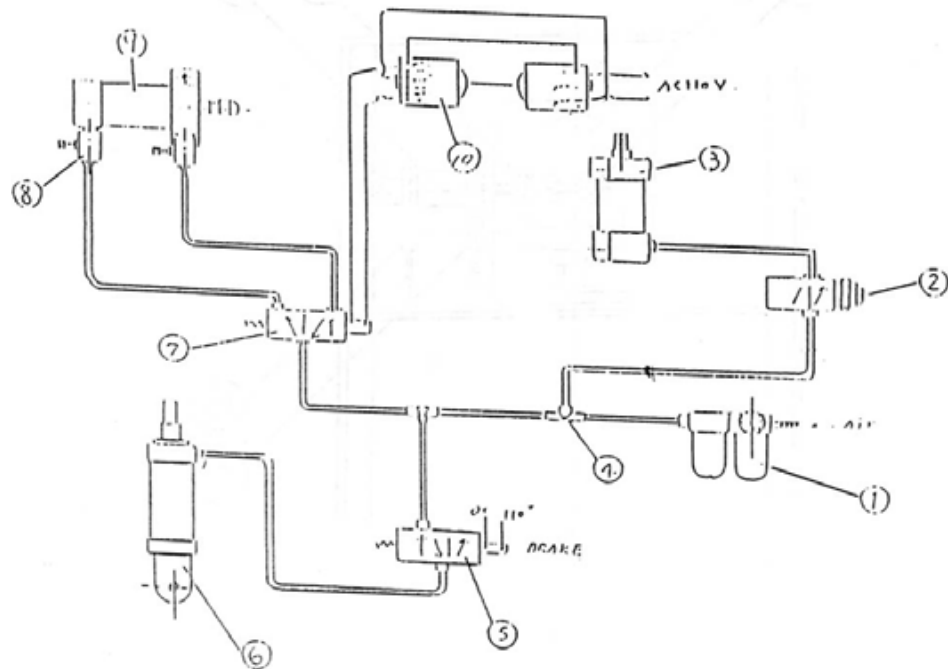

ADJUSTING THE PLATEN

The combination head sander contains a flat platen behind the contact drum.

The combination head sander can be operated in 3 modes:

1. Platen up (Fig. 1): The sander functions as a drum only machine.
2. Platen in level position with the contact drum (Fig. 2): Contact drum and platen are both working.
3. Platen down (Fig. 3): The platen below contact drum is frequently used for final finish with finer grits of sandpaper.

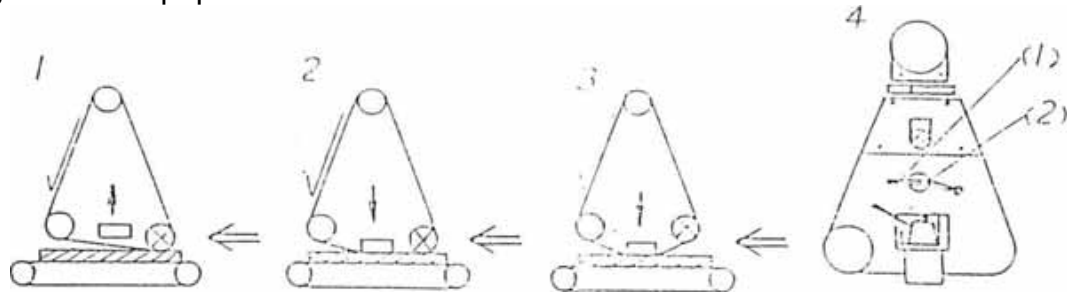

How to Adjust the Platen Up and Down (Fig. 4):

1. Loosen the fixed screw (1) by handle.
2. Remove the adjusting lever by handle (2) to move the sanding pad upward or downward.
3. Tighten the handle (1) after the sanding pad is in correct position.

NOTE:

1. The platen should not be moved downward too much, since otherwise the sanding belt could be clogged too quickly or cause burns on belt and work piece.
2. After sometime the height of platen should be re-adjusted when the sanding belt has worn off a little.
3. Don't forget to fix handle (1) after adjustment.

CHANGING ABRASIVE BELT

1. Open the main aircock.
2. Move turning switch downward, by which the tension roller is lowered.
3. The quick release handle is to be turned to the front and pull it upwards. Now supporting lock is to be removed.
4. Remove the old belt and insert a new one beginning at the tension roller and afterwards the contact roller or sanding pad.

NOTE:

- See to it that the arrows at the inner side of the belt match with the direction of rotation of the aggregate, which is indicated by an arrow on the safety cap of the tension roller.
 - See to it that the edges of the sanding belt are not damaged during the fitting.
 - See to it that the sanding belt is between the electric eye.
 - Also take care that the sanding belt does not touch the belt safety switches.
5. Replace the supporting block and fix it again by means of the quick release handle.
 6. Move turning switch upward to place tension on the belt.
 7. Now the motor is to be started and immediately shut off to check that the sanding belt runs correctly and the oscillation works properly.

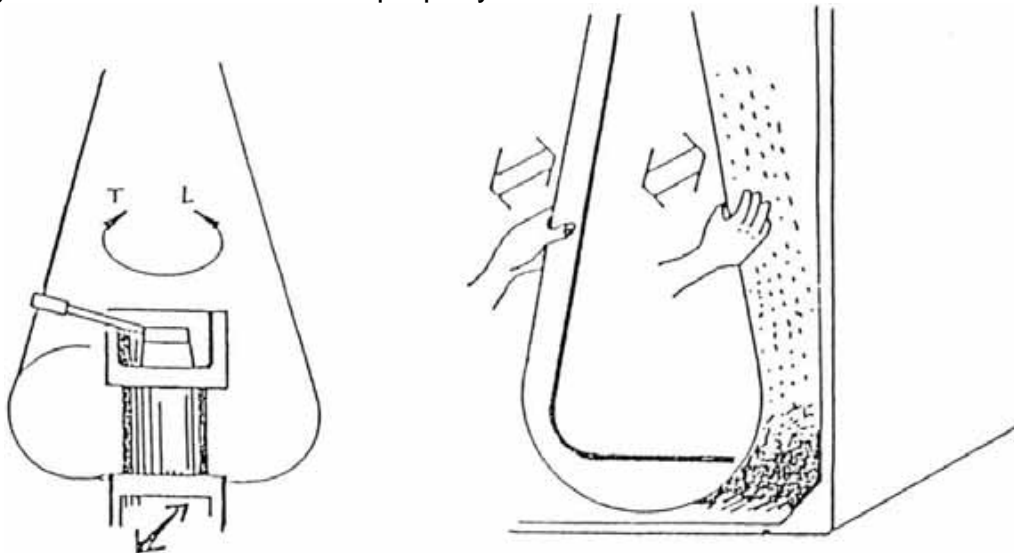

GENERAL MAINTENANCE OF THE CONVEYOR BELT

1. Tension of the Conveyor Belt:
 - A. The feeding conveyor has auto tracking by limit switch and air cylinder.
 - B. The conveyor belt can be adjusted, if it is too loose, with the socket wrench provided.
 - C. We do not recommend tightening the conveyor belt, as this affects the life of the belt.
2. Re-conditioning of the Conveyor Belt:

This should be done if the surface of the belt is too smooth, so that the work piece is slipping or if the surface of the belt shows irregularities.

 - A. Apply a sanding belt with 60 grit or coarser.
 - B. Put the table on the lowest position.
 - C. Put the front pressure roller on position 0.
 - D. Switch off the table floating (if on machine).
 - E. Switch on the main motor together with the feed motor.
 - F. The table is to be raised slowly.
 - G. The conveyor belt should be sanded off as little as possible. See to it that the whole surface is touched.
 - H. Lower the table about 3mm, then switch off the main motor and feed motor.

NOTE: Sanding of the conveyor belt can be properly done if the contact drum is parallel to the table and the pressure roller.

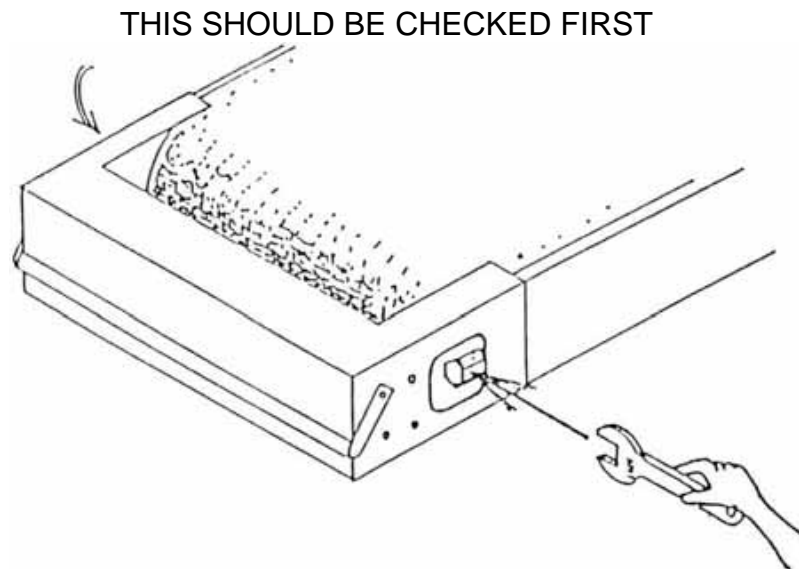

MAINTENANCE OF THE AIR UNIT

1. Daily Maintenance: Remove condensation water from air filter.
2. Monthly Maintenance:
 - A. Clean the inside of the plastic housing with a dry rag. Do not clean with detergent or other liquid.
 - B. Remove brass filter unit and clean with acetone or petrol and air pistol.
3. Clean the electric eye with dry rag.

GREASING & LUBRICATION

1. Check all oil and grease nipples weekly.
2. Check oil tank level monthly.
3. Check the gearbox yearly.
4. Lubricate the shaft and the bushing of the tension unit regularly.
5. First month only:
 - Drain out oil and change with new oil after the first month of operation. In running period, change oil at 2500 hours or 6-month intervals, whichever comes first.

DISTURBANCES

Disturbances	Possible Cause	Solution
The machine does not run	Fuses are blown	Insert a new fuse
	Not enough tension on sanding belt	Use turning switch to apply tension to belt
	Emergency stop button still pressed in	Press button again
	Pressure is too low	Check the air supply unit
	Thermal relay switched off	Press the button of the thermal relay
	Sanding belt touching the belt protection switch	Push the belt backwards
Machine repeatedly stops	Irregular air supply	Check air supply unit and remedy any disturbances
	Water in the air unit	Draw off the water
	Overload of the sanding aggregate	Remove less material during sanding
	Rattling of the sanding belt against the forks of the auto belt protection	Check sanding belt and replace if necessary. Adjust belt protection somewhat wider
Sanding belt runs off to one side	Speed control valve is not correctly adjusted	To be re-adjusted
	Oscillation of the belt is not correct	To be re-adjusted
Slipping of the conveyor belt	Contact roller is too high	Lower the contact roller

DEFICIENCIES DURING THE SANDING OPERATION

1. The stock to be sanded is thinner at the beginning.
CAUSE:
 - The rear pressure bar is too low in relation to the contact roller.
2. The stock to be sanded is thinner at the end.
CAUSE:
 - The front pressure bar is too low in relation to the contact roller.
3. The sanding paper clogs too quickly.
CAUSE:
 - The grit of the sanding paper is too fine.
 - Too much material is sanded off.
 - The wood is too oily and clogs the abrasive grains too quickly.
 - The exhaust is insufficient.
 - There is too much dirt or glue on the wood.
 - The wood is too moist.
4. When sanding veneers it sands through too quickly.
CAUSE:
 - The front pressure bar is not fixed.
 - The front pressure bar is too high.
5. Too much rounding occurs along the edges when solid wood is sanded.
CAUSE:
 - Too much material is removed so that the contact roller is pressed too much.
6. There are differences in thickness between the left and the right side of the work piece.
CAUSE:
 - The table is not in correct position in relation to the contact roller.
 - The front pressure bar is not in a correct position in relation to the contact roller.
7. There are differences in thickness between the front and backsides of the work piece.
CAUSE:
 - Through feed speed is too high.
 - Too much stock is being removed.
 - The sanding paper is too fine in relation to the stock removal.
8. The work piece slips on the conveyor belt.
CAUSE:
 - Too little pressure between the pressure bar, work piece and/or table, work piece.
 - When sanding veneers, too little table pressure.
 - Conveyor belt is too smooth.
 - Too much dust on the conveyor belt.
 - The rear pressure bar is too low, so that this stops the work piece.

DEFICIENCIES IN THE SANDING PATTERN

1. Notches or grooves in the work piece straight strip

CAUSE:

- Dirty pressure bar



2. Snake marks on a part of the work piece

CAUSE:

- Local damage of the sanding belt

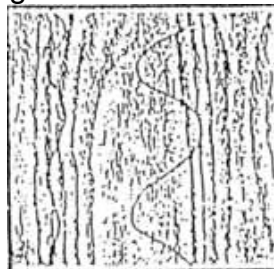

3. Straight parallel running stripes over the entire width of the work piece

CAUSE:

- Joint of the sanding belt is too thick or open



4. Gleaming spots on the wood

CAUSE:

- The sanding belt is too old
- The rear pressure bar is too low
- The contact roller is too high

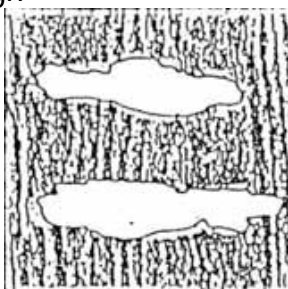

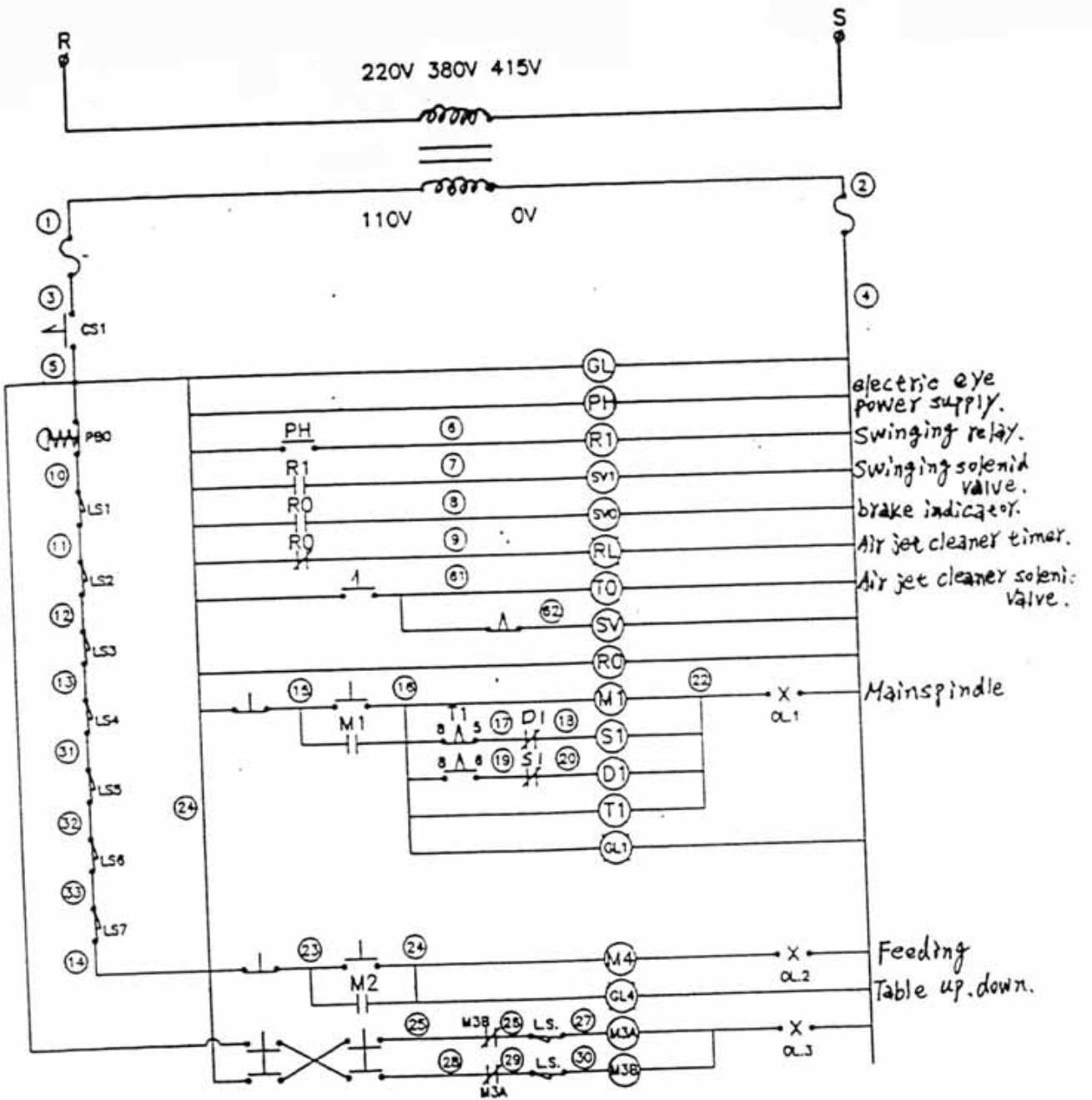

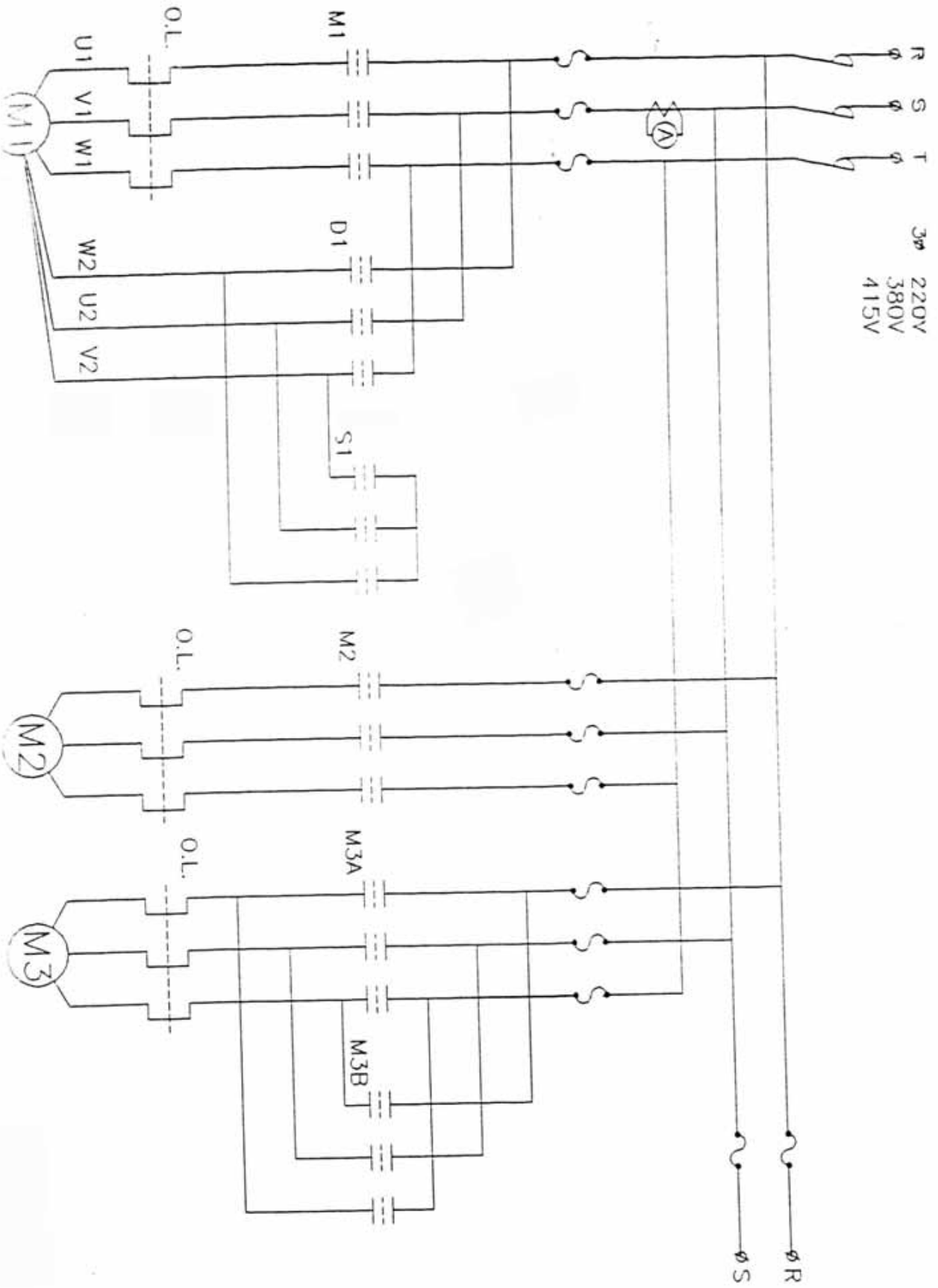

MAIN FRAME GROUP

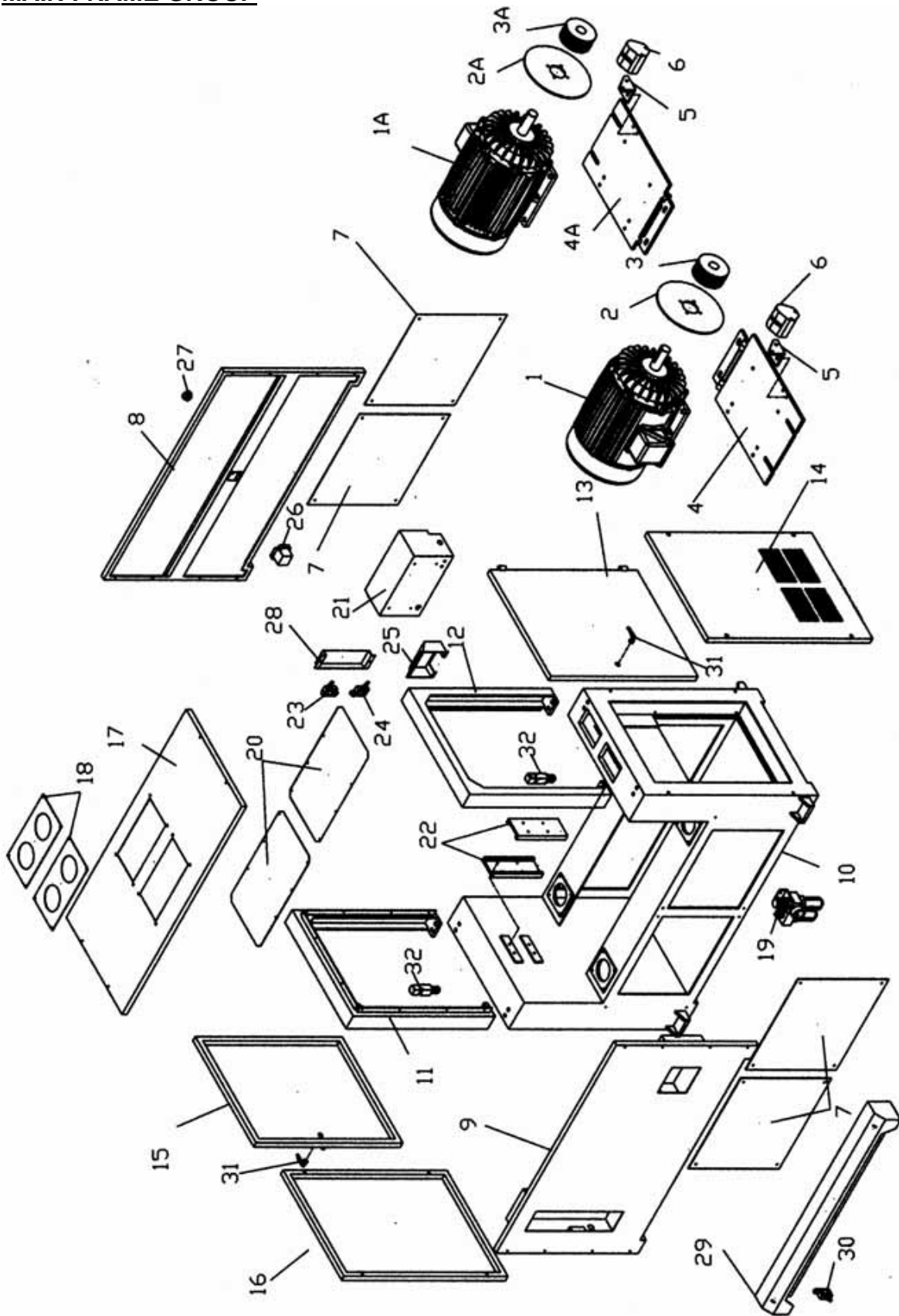

Main Frame Group

No	Part Name	Qty	Part No
1	Main Motor of First Head	1	30HP
1A	Main Motor of Second Head	1	30HP
2	Brake Disk of First Head	1	12" Diameter
2A	Brake Disk of Second Head	1	12" Diameter
3	Main Motor's Pulley of First Head	1	B150X3G
3A	Main Motor's Pulley of Second Head	1	A137X4G
4	Main Motor's Base of First Head	1	4S521027
4A	Main Motor's Base of Second Head	1	4S521027
5	Brake Fixed Plate	4	4S241012
6	Brake Set	4	BL-44
7	Lower Door (Front & Rear)	4	4S521138
8	Upper Door (Rear)	1	4S521140
9	Upper Door (Front)	1	4S521139
10	Main Frame	1	1S521136
11	Upper Cover Support (Left)	1	4S421197
12	Upper Cover Support (Right)	1	4S421198
13	Upper Door (Right)	1	4S421201
14	Lower Door (Right)	1	3S421205
15	Upper Door (Left)	1	4S421199
16	Lower Door (Left)	1	4S421204
17	Top Cover	1	4S521141
18	Dust Collector-Fix-Cover	2	4S361054
19	Air Regulator	1	3/8"
20	Cover	2	4S521137
21	Air Control Box	1	4S421208
22	Slider A	2	4S361018
23	Table Upper Limit Switch	1	TZ-7311
24	Table Lower Limit Switch	1	TZ-7311
25	Wire Box	1	3S361078
26	Emergency Cover	1	4S361259
27	Emergency Button	1	TE Switch
28	Upper Down Limit Switch Cover	1	4S361045
29	Over Thickness Safety Bar	1	3S521142
30	Limit Switch	1	TZ-7310
31	Handle	2	Seven Star Item
32	Interlock Safety Cutoff	2	D4DS-15FS

HOISTING JACK SCREW GROUP

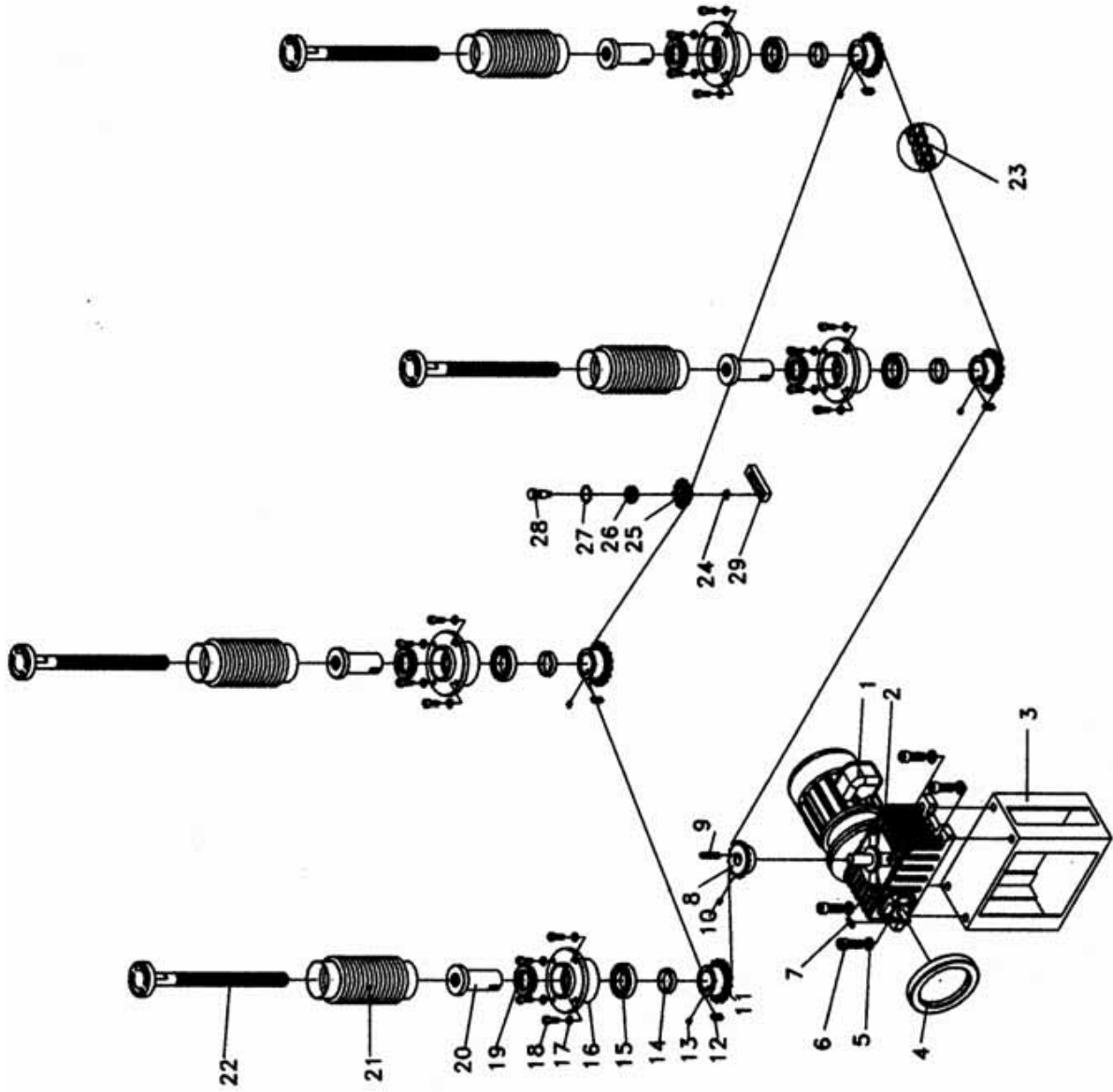

Hoisting Jack Screw Group

No	Part Name	Qty	Part No
1	Hoisting Motor	1	1/2HP
2	Hoisting Gear Reducer	1	KE60.1/60
3	Gear Reducer Support	1	4S421182
4	Hand Wheel	1	4S361012
5	Spring Washer	4	M12
6	Hex. Socket Cap Bolt	4	M12X1.75X30L
7	Key	1	5X5X25L
8	Chain Sprocket (Gear Reducer)	1	4S361007
9	Key	1	7X7X45L
10	Hex. Socket Cap Bolt	1	M6X1.0X20L
11	Chain Sprocket (Up & Down)	4	4S361006
12	Key	4	8X8X25L
13	Hex. Socket Cap Bolt	4	M8X1.25X10L
14	Collar	4	4S361004
15	Ball Bearing	4	#6008ZZ
16	Bearing Housing	4	4S361002
17	Spring Washer	16	M8
18	Hex. Bolt	16	M8X1.25X25L
19	Bearing	4	#51108
20	Lead Screw Nut	4	4S361003
21	Protection Tube	4	3"
22	Lead Screw	4	4S361005
23	Chain	1	#425
24	C-Ring	1	S-15
25	Chain Sprocket (Idler)	1	4S361009
26	Ball Bearing	1	#6002ZZ
27	C-Ring	1	R-32
28	Chain Sprocket Shaft (Idler)	1	4S361010
29	Chain Sprocket Shaft Support	1	4S361011

WORKING TABLE GROUP

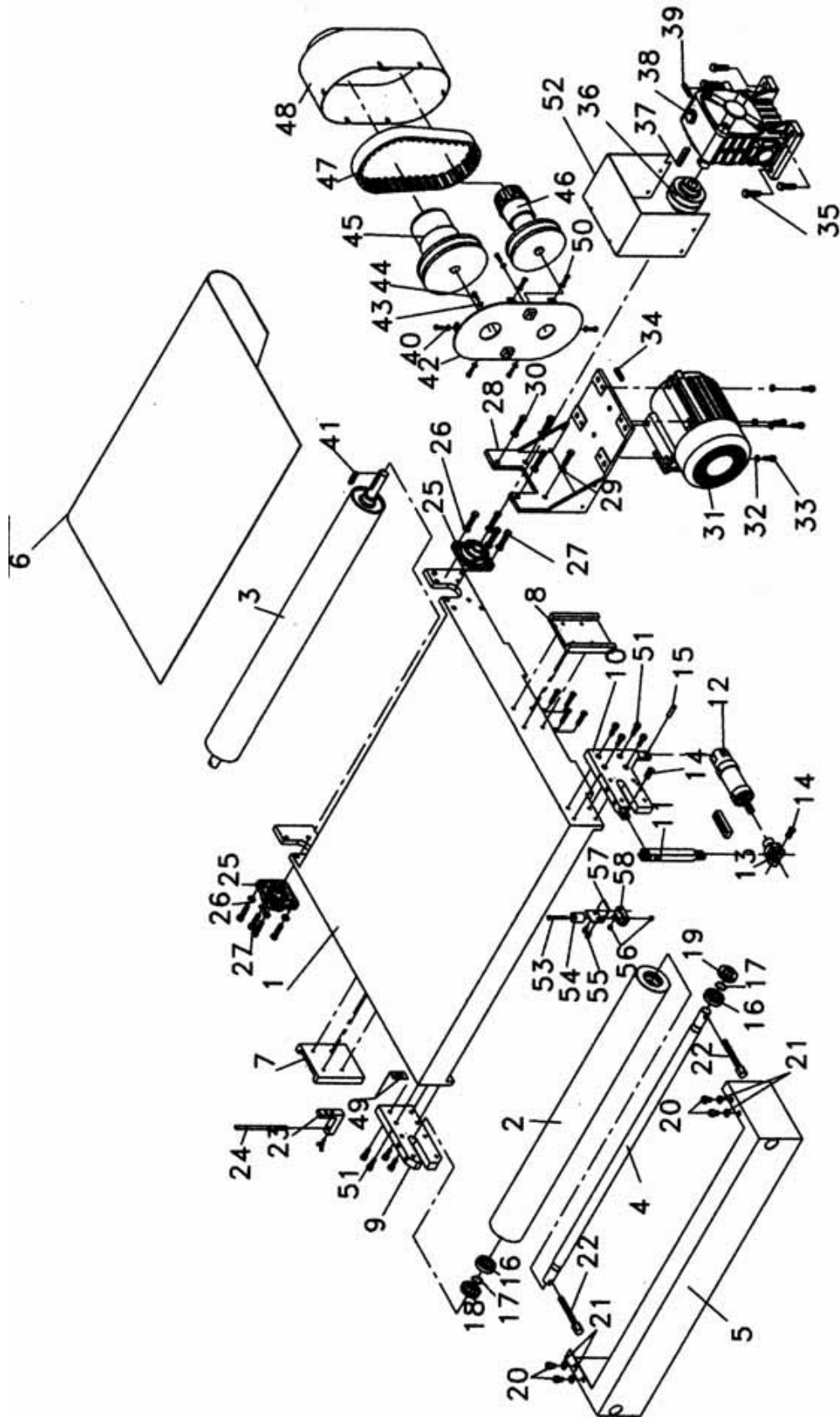

Working Table Group

No	Part Name	Qty	Part No
1	Table	1	2S521089
2	Front Feed Roller Tube	1	4S521091
3	Rear Feed Roller	1	4S521092
4	Front Feed Roller Shaft	1	4S521090
5	Front Feed Roller Cover	1	3S521156
6	Conveyor Belt	1	W1270mmXL3330mm
7	Slider B	1	4S241021
8	Slider B	1	4S251021
9	Front conveyor Roller Support/L	1	4S361021
10	Front Conveyor Roller Support/R	1	4S361022
11	Oscillating Rod	1	4S361028
12	Air Cylinder	1	CB-50X25SD
13	Y Adapter	1	#50
14	Rod Pin	2	4S361029
15	Rod Pin	1	4S361030
16	Bearing	2	#6205ZZ
17	C-Ring	2	S-25
18	Bearing Cover (Left)	1	4S361055
19	Bearing Cover (Right)	1	4S361055
20	Hex. Socket Cap Bolt	4	M10X1.5X20L
21	Washer	4	M10
22	Adjusting Screw	2	4S361026
23	Touching Bar Support	1	4S361043
24	Touching Bar	1	4S361042
25	Pillow Block Bearing	2	UCF-206
26	Washer	8	M10
27	Hex. Socket Cap Bolt	8	M10X1.5X30L
28	Gear Reducer Seat	1	3S361090
29	Washer	4	M12
30	Hex. Bolt	4	M12X1.75X30L
31	Feed Motor	1	3HP-4P
32	Washer	4	M10
33	Hex. Bolt	4	M10X1.5X30L
34	Key	4	8X7X40L
35	Hex. Socket Cap Bolt	4	M12X1.75X40L
36	Coupling	1	#5018
37	Key	1	10X8X70L
38	Gear Reducer/Feed	1	#100,1/60
39	Key	1	7X7X45L
40	Washer	6	M6
41	Key	1	8X8X40L
42	Driven Pulley Cover Support	1	4S421031
43	Washer	2	M6
44	Hex. Socket Cap Bolt	2	M6X1.0X30L
45	Driven Pulley	1	AH-3-B
46	Driven Pulley	1	PH-3-A
47	Vari-Speed Belt	1	V
48	Driven Pulley Cover	1	4S421029
49	Indication Plate	1	4S361040
50	Hex. Socket Cap Bolt	6	M6X1.0X16L
51	Hex. Socket Cap Bolt	8	M8X1.25X30L
52	Coupling Cover	1	4S421207
53	Hex. Socket Cap Bolt	1	M6X1.0X50L
54	Idle PU Roller	1	4S361104
55	Hex. Head Bolt	2	M6X1.0X10L
56	Hex. Nut	2	M6X1.0
57	Air Valve Seat	1	4S361103
58	Air Valve	1	MSV86322R

C HEAD GROUP

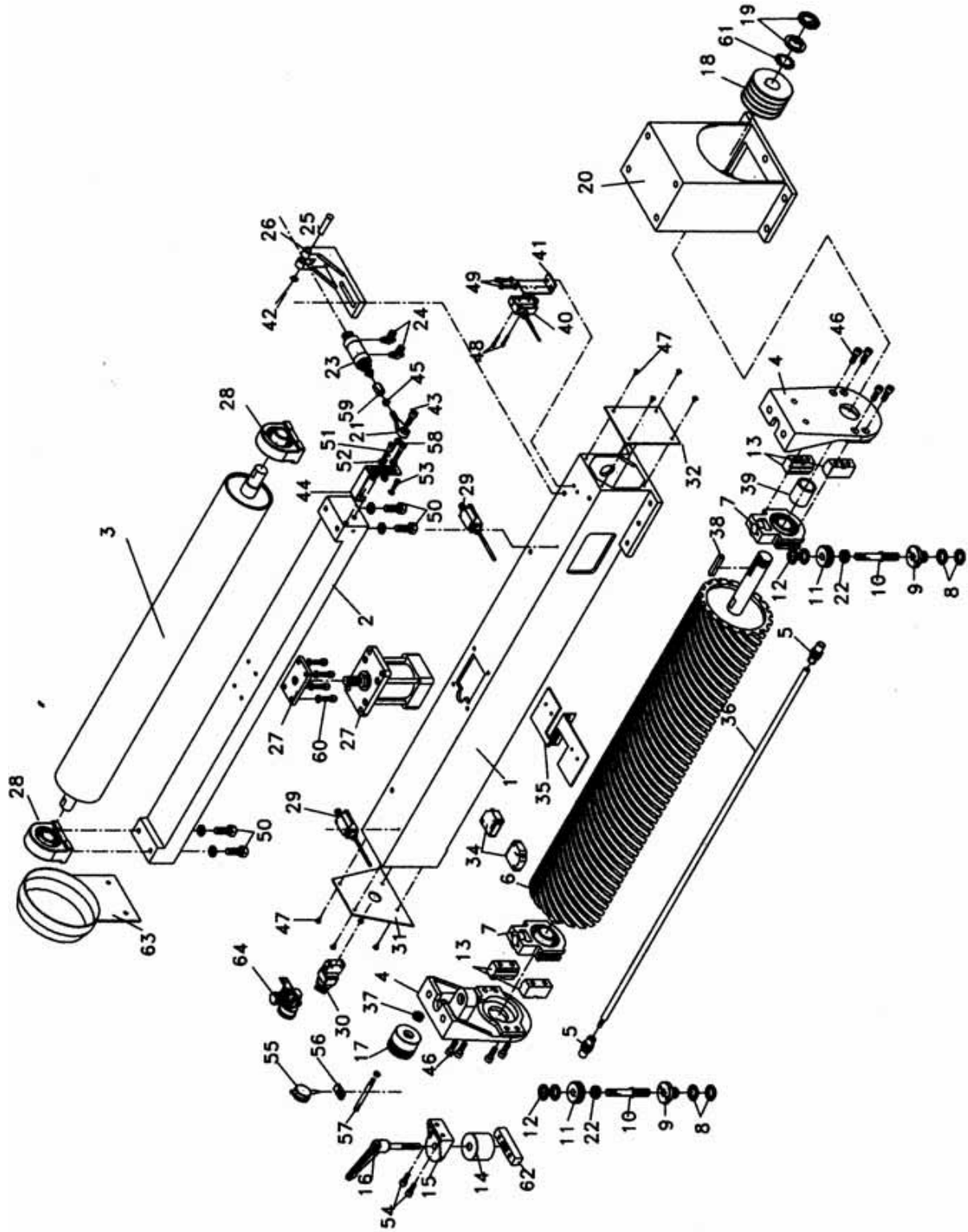

C Head Group

No	Part name	Qty	Part No
1	Cantilever	1	3S523055
2	Tracking Roller Support	1	3S523056
3	Idle Steel Roller	1	4S523058
4	Rubber Roller Right Support	1	3S363005
	Rubber Roller Left Support	1	3S363004
5	Worm (Left)	1	4S363014
	Worm (Right)	1	4S363015
6	Contact Drum	1	3S523057
7	Pillow Block Bearing	2	UCT-207
8	Hex. Screw	4	4S363018
9	Adjusting Hex. Screw	2	4S363019
10	Adjusting Screw	2	4S363020
11	Worm Gear	2	4S363016
12	Hex. Screw	4	4S243008
13	Slide Block	4	4S363012
14	Spacer	1	4S363010
15	Fix Support (Cantilever)	1	4S362006
16	Angle Screw	1	M14X2.0X90L
17	Hand Wheel	1	4S523014
18	Pulley	1	B125X3G
19	Pulley Hex. Screw	2	4S363008
20	Cantilever Seat	1	3S423066
21	Bearing	1	POS-14L
22	Bearing	2	#51102
23	Tracking Cylinder	1	50X5SD
24	Air Speed Control	2	1/4"
25	Tracking Cylinder Pin	1	4S423013
26	Tracking Cylinder Seat	1	4S423007
27	Tension Cylinder	1	FA-100X40SD
28	Pillow Block Bearing	2	UCPA-207
29	Limit Switch	2	TZ-8168
30	Turning Switch (Into Air)	1	AVS138-935
31	End-Cover-Cantilever (Left)	1	4S423070
32	End-Cover-Cantilever (Right)	1	4S423071
34	Electric Eye	1	E3JK-5DM2
35	Electric Eye Support Plate	1	4S362042
36	Shaft/Contact Drum Up & Down	1	4S523059
37	Bearing	1	#51100
38	Key	1	10X8X40L
39	Spacer	1	4S363041
40	Limit Switch	1	MN-5166
41	Limit Switch Fixed Seat	1	4S362068
42	Buckle Ring	1	S-12
43	Hex. Socket Cap Bolt	1	M14X2.0X35L
44	Switch Plate	1	3S362066
45	Hex. Nut (Left Screw)	1	M14X2.0
46	Hex. Socket Cap Bolt	8	M10X1.5X30L
47	Hex. Socket Cap Bolt	8	M5X0.8X8L
48	Hex. Socket Cap Bolt	2	M4X0.7X25L
49	Hex. Socket Cap Bolt	2	M6X1.0X10L
50	Hex. Socket Cap Bolt	4	M14X2.0X30L
51	HEX. Socket Cap Bolt	2	M8X1.25X50L
52	Hex. Nut	4	M8X1.25
53	Hex. Socket Cap Bolt	1	M6X1.0X10L
54	Hex. Socket Cap Bolt	2	M8X1.25X10L
55	Dial Indicator	1	1044F (5mm)
56	Dial Indicator Fixed Seat	1	4S522035
57	Dial Indicator Fixed Rod	1	4S522036
58	Hex. Nut	1	M14X2.0
59	Adjusting Nut	1	4S423014
60	Hex. Socket Cap Bolt	4	M10X1.5X25L
61	Plum blossom Type Washer	1	35 HOLE
62	Quick Release & lock Bolt Seat	1	4S361251
63	End-Cover-Sanding Belt	1	4S363048
64	Air Pressure Valve	1	1/8" Hole

P HEAD GROUP

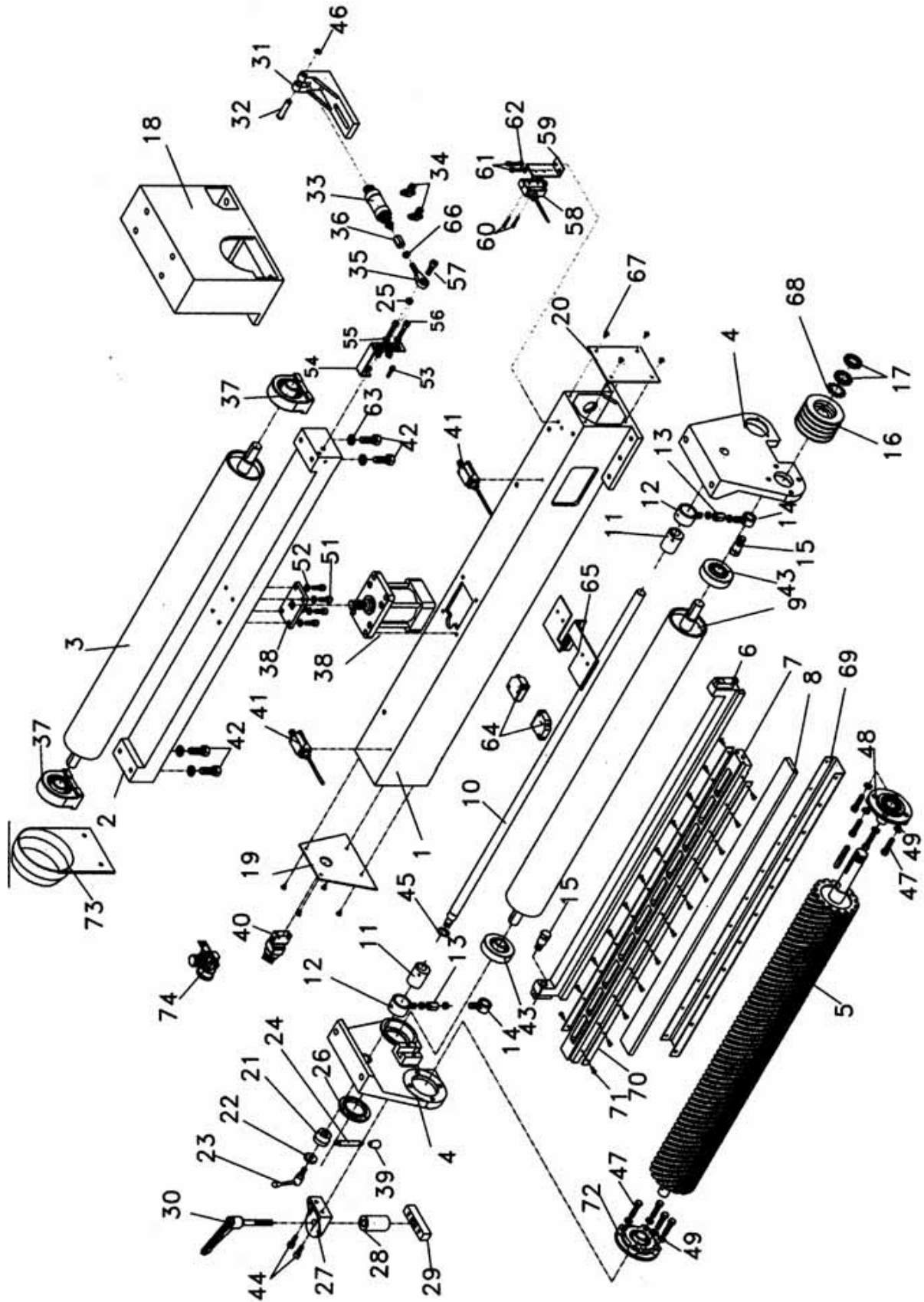

P Head Group

No	Part Name	Qty	Part No
1	Cantilever	1	3S522045
2	Tracking Roller Support	1	3S522046
3	Idle Steel Roller	1	4S522049
4	Rubber Roller Left Support	1	3S362004
	Rubber Roller Right Support	1	3S362005
5	Contact Drum	1	3S522047
6	Top Slider (Platen Assembly)	1	3S522051
7	Bottom Slider (Platen Assembly)	1	3S522052
8	Pad (Woolen)	1	W2"XL1385mm
9	Idle Steel Roller	1	3S522048
10	Shaft/Platen Up & Down	1	4S522050
11	Eccentric Collar	2	4S362011
12	Upper-Adjusting Screw Ring	2	4S362012
13	Adjusting Nut	2	4S362014
14	Down-Adjusting Screw Ring	2	4S362013
15	Screw Pin	2	4S362015
16	Pulley	1	A102X4G
17	Locking Nut	2	4S362024
18	Cantilever Seat	1	3S362099
19	End-Cover-Cantilever (Left)	1	4S422046
20	End-Cover-Cantilever (Right)	1	4S422045
21	Hoist Sleeve	1	4S362021
22	Sleeve Fastened Collar	1	4S362023
23	Angle Screw	1	M10X1.5X20L
24	Sleeve Handle Bar	1	4S362022
25	Hex. Nut	1	M14X2.0
26	Bearing Cover	1	4S362019
27	Fix Support (Cantilever)	1	4S362006
28	Spacer	1	4S362007
29	Quick Release & Lock Bolt Seat	1	4S361251
30	Angle Screw	1	M14X2.0X110L
31	Tracking Cylinder Seat	1	4S423007
32	Tracking Cylinder Pin	1	4S423013
33	Tracking Cylinder	1	50X5SD
34	Air Speed Control	2	1/4"
35	Bearing	1	POS-14L
36	Adjusting Nut	1	4S423014
37	Pillow Block Bearing	2	UCPA-207
38	Tension Cylinder	1	FA-100X40SD
39	Plastic Head	1	5/16" Hole Screw
40	Turning Switch (Into Air)	1	AVS 138-935
41	Limit Switch	2	TZ-8168
42	Hex. Socket Cap Bolt	4	M14X2.0X35L
43	Pillow Block Bearing	2	UCC-206
44	Hex. Socket Cap Bolt	2	M8X1.25X20L
45	C-Ring	1	S-22
46	C-Ring	1	S-12
47	Hex. Head Bolt	8	M10X1.5X40L
48	Pillow Block Bearing	1	UCFC-206
49	Washer	8	M10
51	Hex. Socket Cap Bolt	4	M10X1.5X30L
52	Washer	4	M10X1.5
53	Hex. Socket Cap Bolt	1	M6X1.0X10L
54	Switch Plate	1	4S362066
55	Hex. Nut	4	M8X1.25
56	Hex. Socket Cap Bolt	2	M8X1.25X50L
57	Hex. Socket Cap Bolt	1	M14X2.0X35L
58	Limit Switch	1	MN-5166
59	Limit Switch Seat	1	4S362068
60	Hex. Socket Cap Bolt	1	4S362068
61	Hex. Socket Cap Bolt	2	M6X1.0X10L
62	Washer	2	M6
63	Washer	4	M14
64	Electric Eye	1	E3JK-5DM2
65	Electric Eye Support Plate	1	4S362042
66	Hex. Nut (Left Screw)	1	M10X1.5
67	Hex. Socket Cap Bolt	8	M5X0.8X10L
68	Plum Blossom Type Washer	1	30HOLE
69	Graphite Canvas	1	5"X54.5"
70	Graphite Canvas Plate	2	1/8"X3/4"X1385mmL
71	Flat Cap Bury Head Bolt	26	M5X0.8X16L
72	Pillow Block Bearing	1	UCFC-205
73	End-Cover-Sanding Belt	1	4S362097
74	Air Pressure Valve (Can Adjusting Pressure)	1	1/8"

TWO HEAD PRESSURE ROLLER GROUP

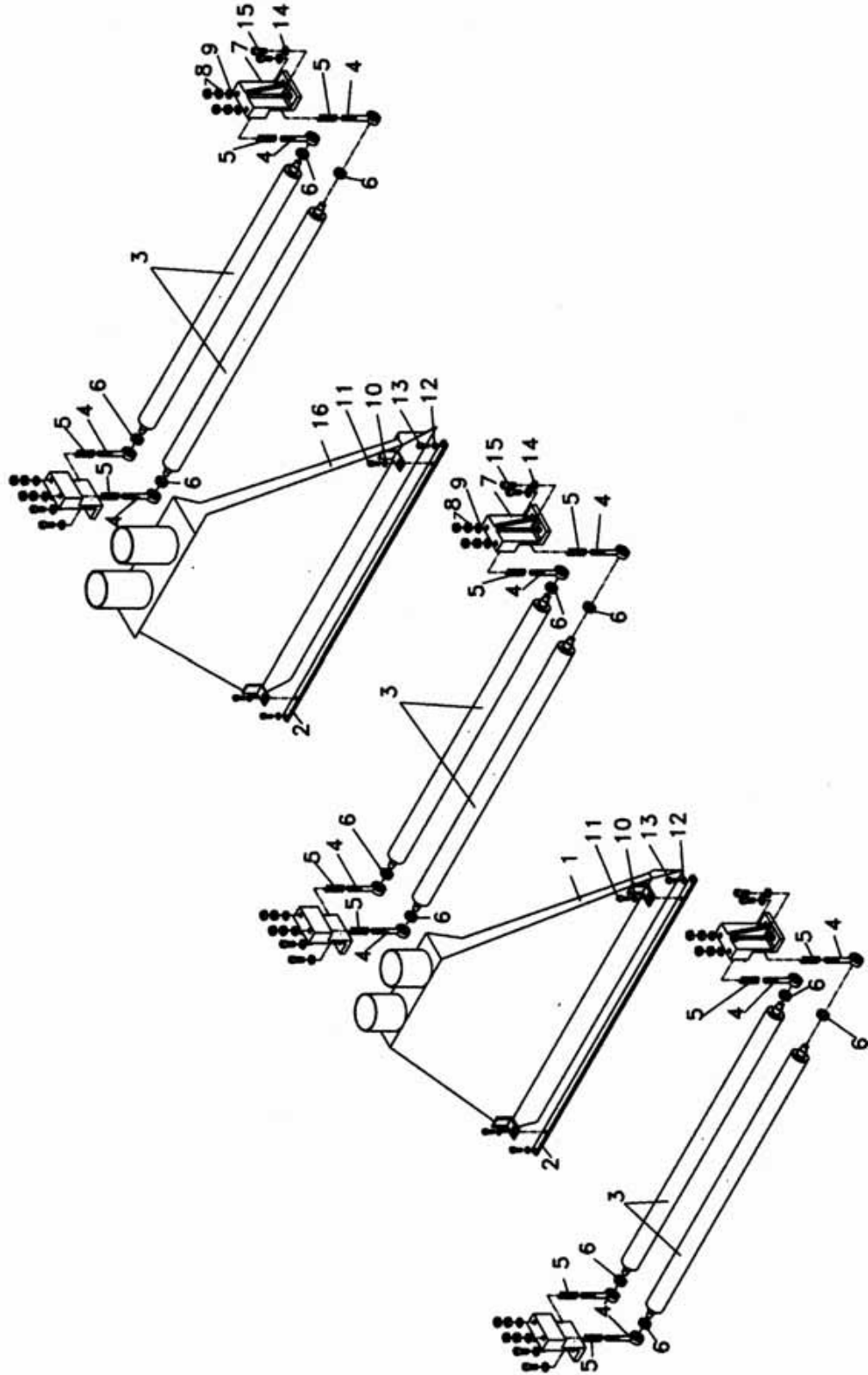

Two Head Pressure Roller Group

No	Part Name	Qty	Part No
1	Dust Collector for P Head	1	3S522053
2	Dust Collector Fixed Plate	2	4S522060
3	Pressure Roller	6	4S524029
4	Bearing Housing	12	4S364003
5	Spring	12	4S364004
6	Bearing	12	#6002-LLU
7	Pressure Roller Support	6	4S364027
8	Adjusting Nut	24	W1/2"
9	Washer	12	W1/2"
10	Washer	4	M8
11	Hex. Socket Cap Bolt	4	M8X1.25X20L
12	Spring Washer	4	M8
13	Hex. Socket Cap Bolt	4	M8X1.25X20L
14	Spring Washer	12	M12
15	Hex. Socket Cap Bolt	12	M12X1.75X30L
16	Dust Collector for C Head	1	3S523060